

Knock-down table plans

Copyright 2019 Matthias Wandel
<http://woodgears.ca>

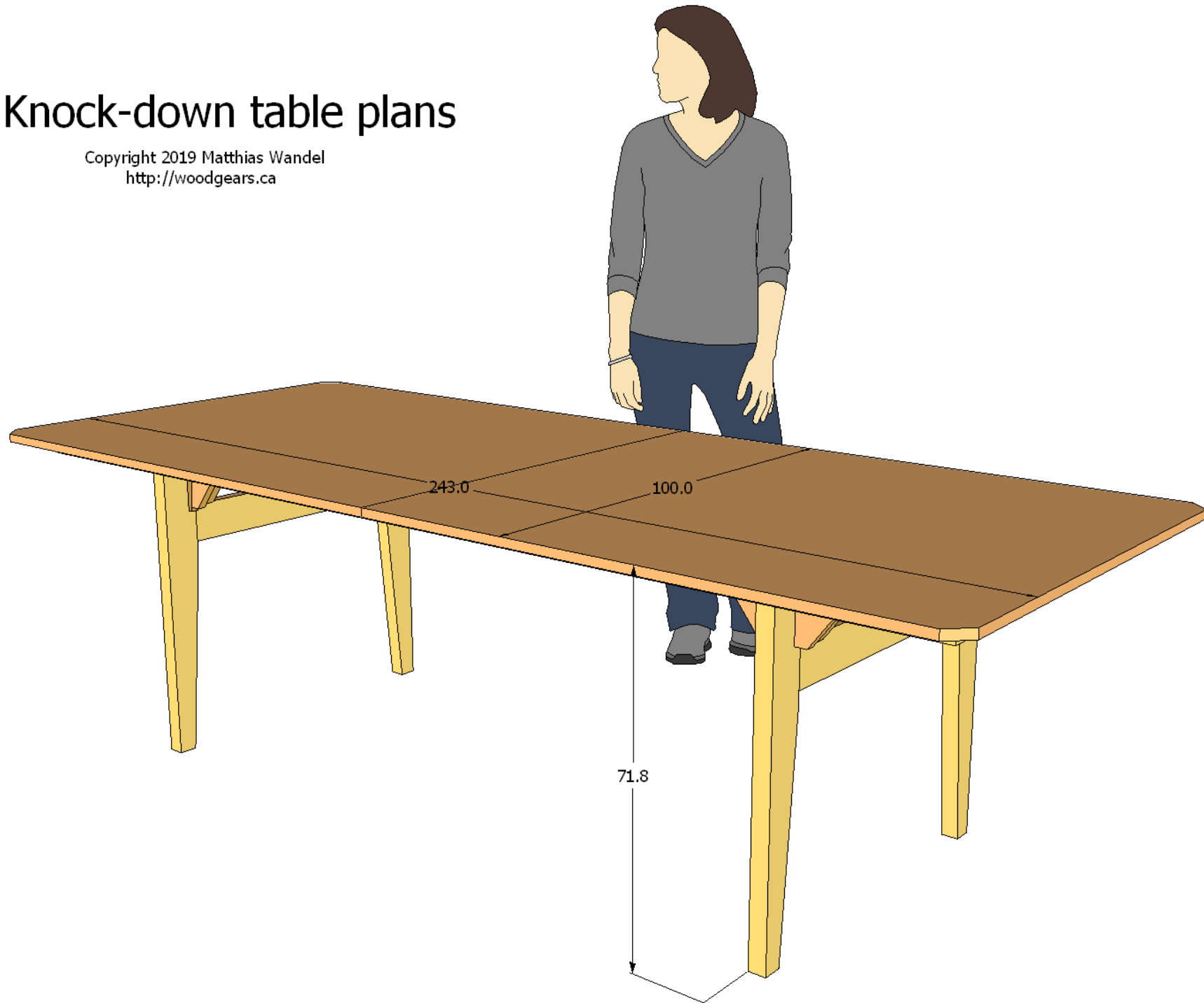

Table parts

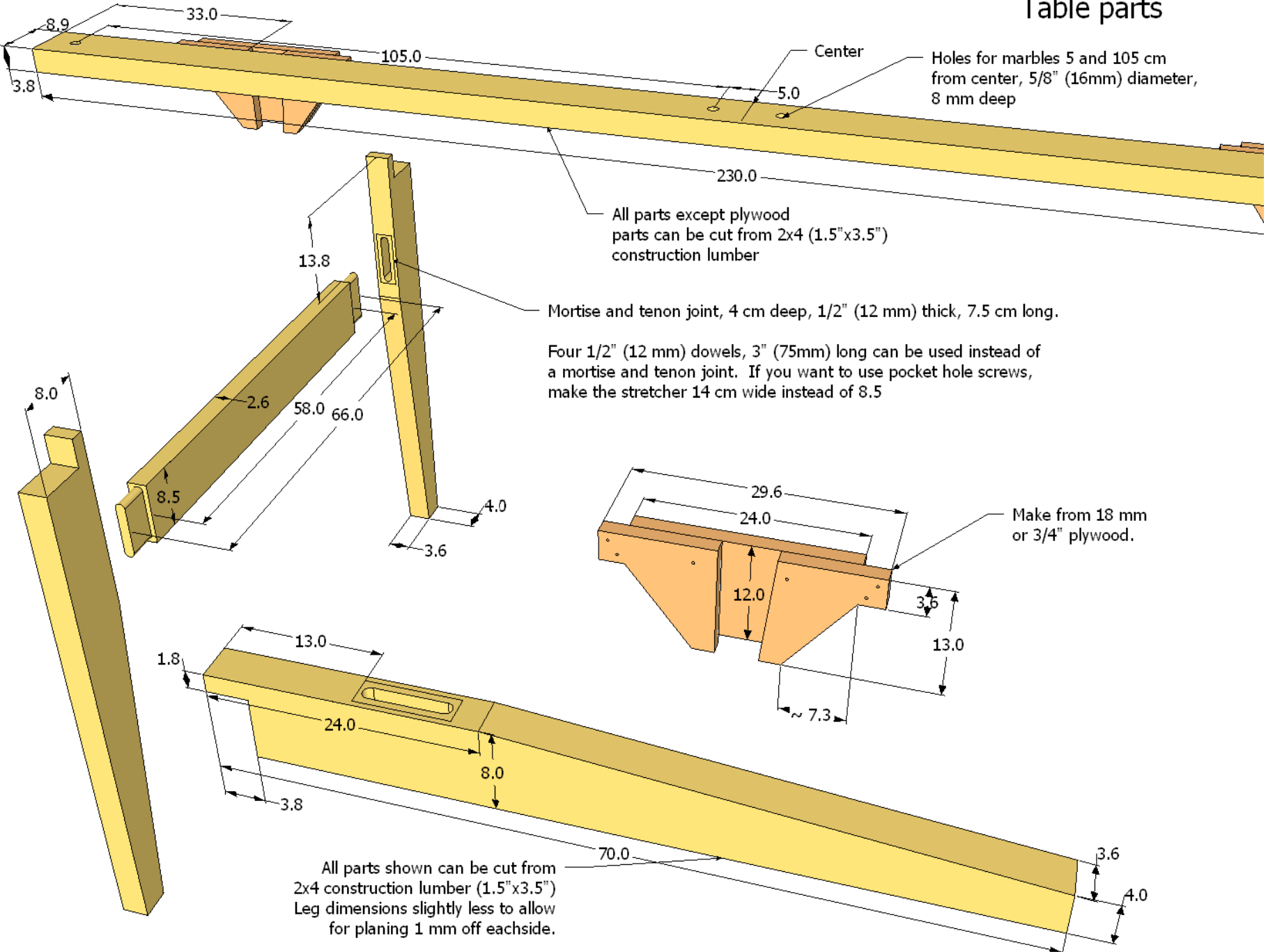
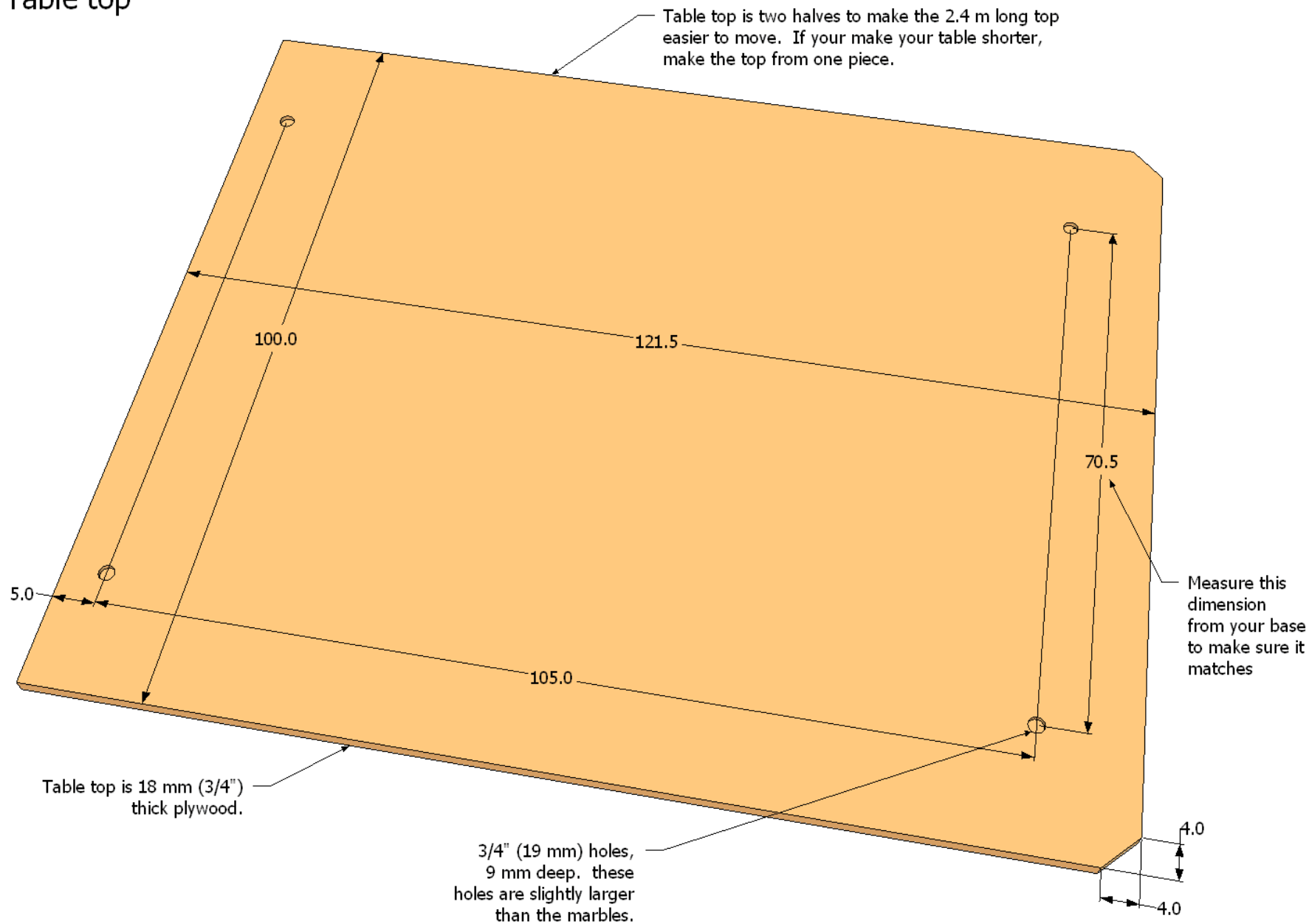
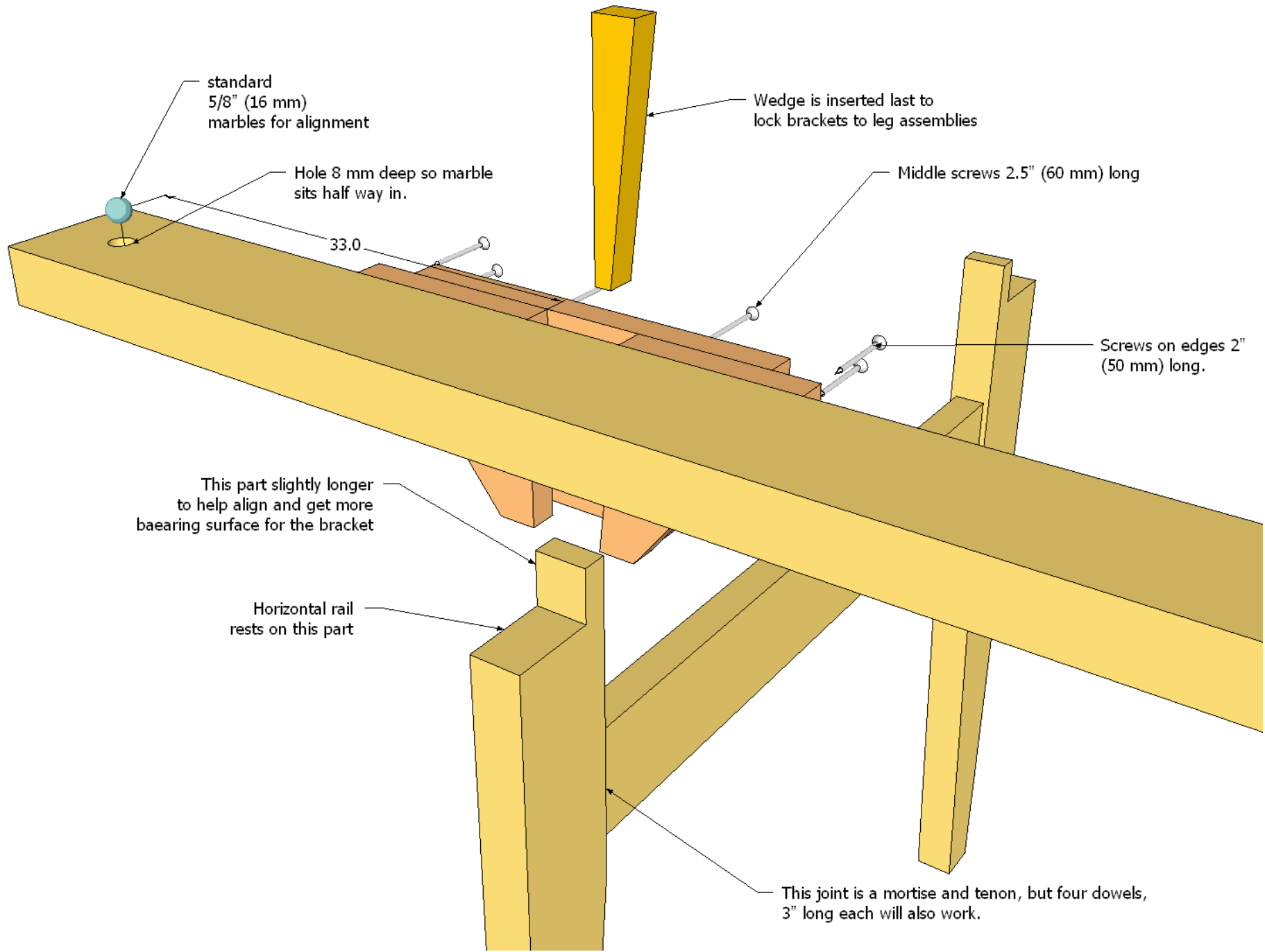

Table top





standard
5/8" (16 mm)
marbles for alignment

Hole 8 mm deep so marble
sits half way in.

33.0

Wedge is inserted last to
lock brackets to leg assemblies

Middle screws 2.5" (60 mm) long

Screws on edges 2"
(50 mm) long.

This part slightly longer
to help align and get more
bearing surface for the bracket

Horizontal rail
rests on this part

This joint is a mortise and tenon, but four dowels,
3" long each will also work.

Leg bracket partial layer and wedge, 1:1

Disable "fit to page" and scaling before printing this PDF.
Check measurements to make sure it is printed 1:1

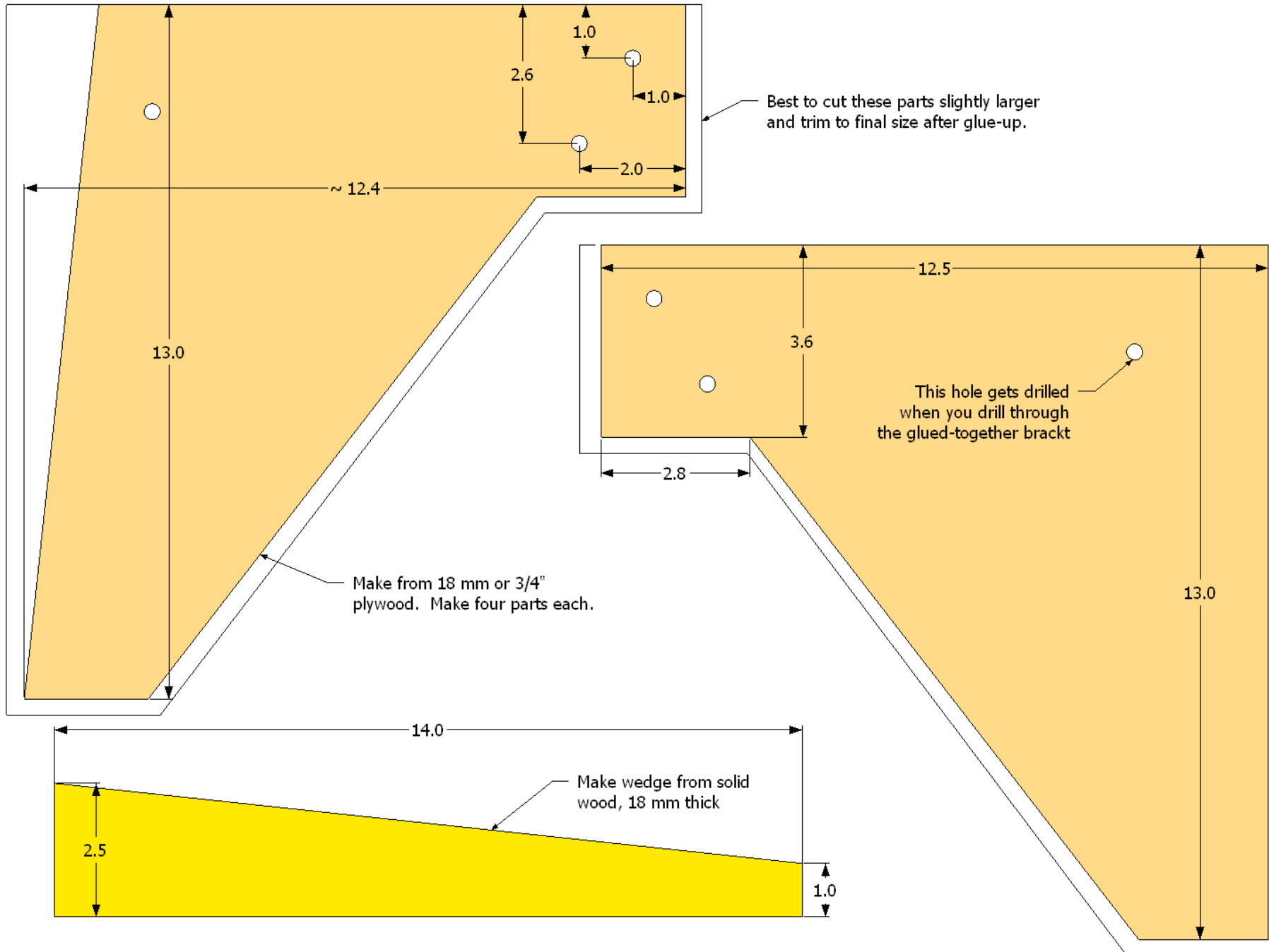

Leg bracket, solid layer, 1:1

Disable "fit to page" and scaling before printing this PDF.
Check measurements to make sure it is printed 1:1

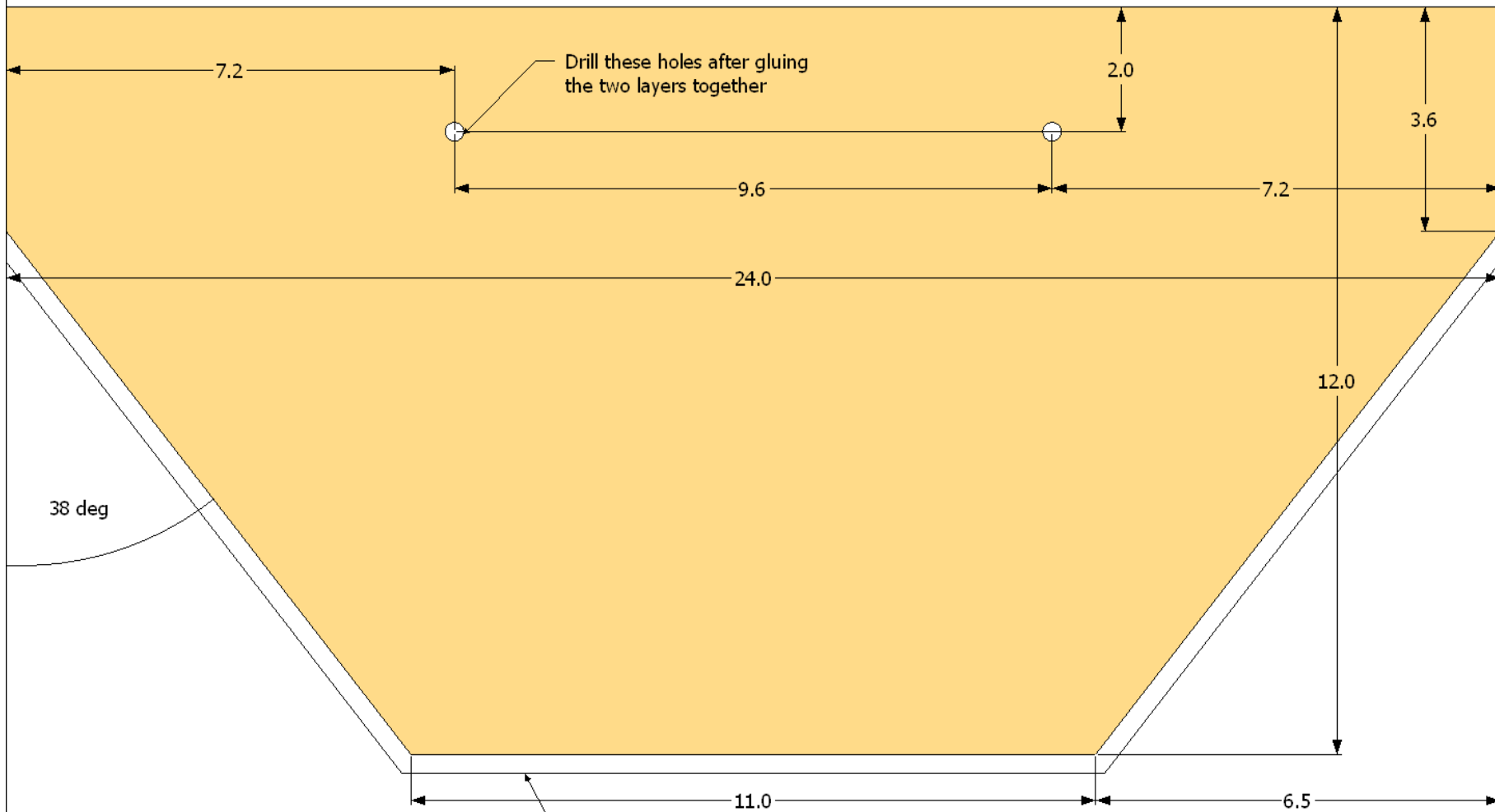

Drill these holes after gluing
the two layers together

38 deg

Make four of these.
Its a good idea to cut these parts
slightly oversized.